

Installation Manual



Classical.



Modern.



The Colourbox Story

About Us

After almost thirty years working with leading manufacturers on the most fabulous projects, we decided to establish a lighting brand which embodied our beliefs, design philosophy and everything we learned on the way.

Our Philosophy

Purity in design.
Excellence in function.
Robust in operation.
Made in the UK.
Sharing knowledge.
Social responsibility.

**MADE IN
BRITAIN** 



**Thank you for choosing British made
Colourbox products.**

**Every light we make matters. So much that we
test each & every one.**

**If you need any help or advice, please call us on
01795 505370. We'd love to hear from you.**

Five Year Guarantee

We test all our lights before we ship them so that you can be assured that our products will be working straight out of the box.

Our technology partners Tridonic, Osram and Bridgelux are world leaders in lighting component manufacturing with peerless R&D and manufacturing quality control.

Colourbox's own stringent development testing ensures all components operate well within their design parameters ensuring the longest working life possible.

Because of this we are able to offer a FIVE Year no quibble guarantee. If one of our lights fails, please let us know and we'll send you a replacement. As simple as that.

5

Index

Guarantee	4
Index	5
Preparation	6
Apollo	7
Apollo Plaster-In	9
Apollo Trimless	11
Cubitt	13
Cubitt Trimless	17
Delta	21
Delta Trimless	23
Ghost Trimless	27
Ghost Trimless Wallwasher	29
Orbit	31
Linear	33
Dimming & Control	38
Twin Downlight Cut Out Info	39

Preparation

1. Insulation

- Colourbox luminaires must not be covered with insulation material.
- Ensure a gap of at least 10mm above the fitted luminaire. (fig1)
- Ensure at least 50mm of free space around the outside of the luminaire. (fig2)
- The driver should NOT be covered by insulation.
- Colourbox products have been tested for use with Thermahood TH140 downlighter covers. (fig3) NB Drivers must be placed away from the luminaire.

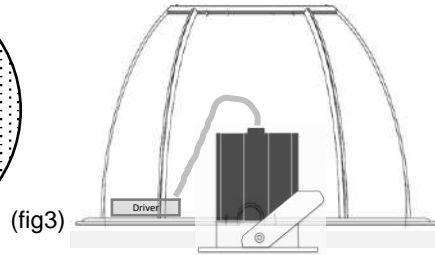
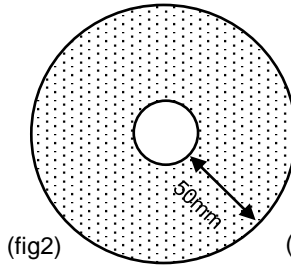
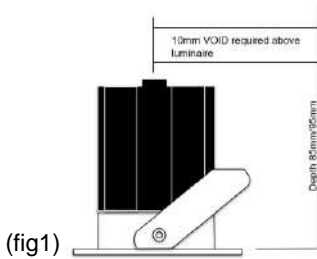

2. Fire Rating



Colourbox have partnered with fire protection experts Envirograf to provide a full fire rating solution for all our downlighter products.

Apollo, Delta, Ghost

Envirograf IDR Fire Safety Collar

Fitted during assembly, the IDR Fire Collar maintains the fire rating of 60min ceilings. It can also be retrofitted if required. (fig4)

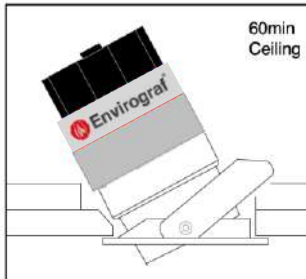

(fig4)



(fig5)

Cubitt / Cubitt Twin

Fire Hood L:130 W:130 H140mm
Bespoke Fire Hood (L:130 W:130 H140mm) (fig5)

Apollo

AB ARF ART AST Cut out Ø 64mm



AB Apollo Base



ARF Apollo Recess Fixed



ART Apollo Recess Tilt

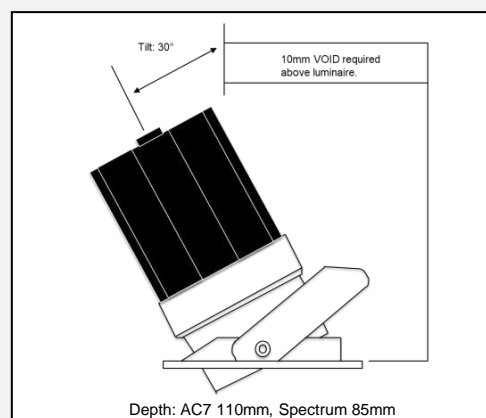
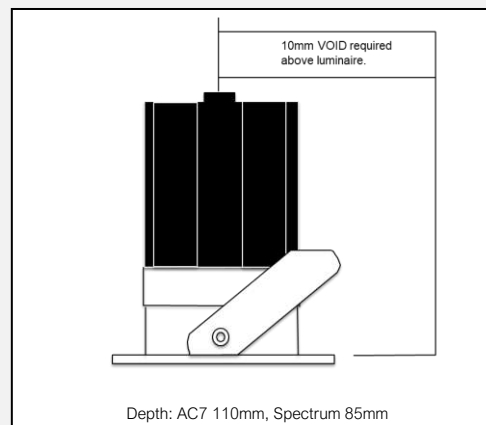
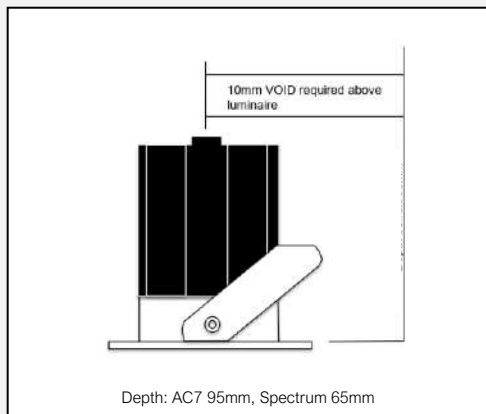

Apollo

AB ARF ART AST Cut out Ø 64mm

- ① Light Engine
- ② Retention Springs
- ③ Luminaire Bezel
- ④ Plasterboard – Upper Layer
- ⑤ Plasterboard – Lower Layer

We recommend Starrett hole saws. 64mm: FCH0212

1. Ensure your electricity supply is disconnected. **DO NOT CONNECT LEDs TO LIVE DRIVERS OR 240V.**
2. Cut your installation hole to the required cut out size. This can be found above and on the product datasheet.
3. Our luminaires are suitable for single and double plasterboard ceilings. If the upper layer of plasterboard prevents the retention springs engaging you will need to cut it back. (4). To achieve full tilt adjustment you may need to cut away the upper layer and chamfer the lower layer of plasterboard (5). (See fig2)
4. LED Connection. **Spectrum** light engines may already be connected to the driver. If not please follow wiring diagram on driver.
5. Mains 240v Connection. If the luminaire has not been pre-wired, please follow the diagram on the supplied driver.
6. **AC7** light engines are 240v and should be connected BLUE cable to NEUTRAL, BROWN cable to LIVE.
7. Offer connected luminaire into the ceiling hole gripping the retention springs (2). Release the springs. Adjust so that the bezel (3) fits snugly in the hole. The bezel (3) can be rotated anti-clockwise to achieve a tighter fit.

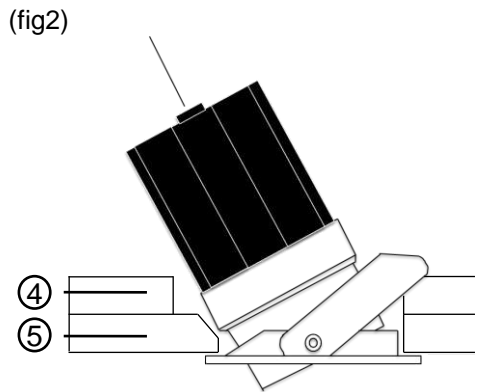
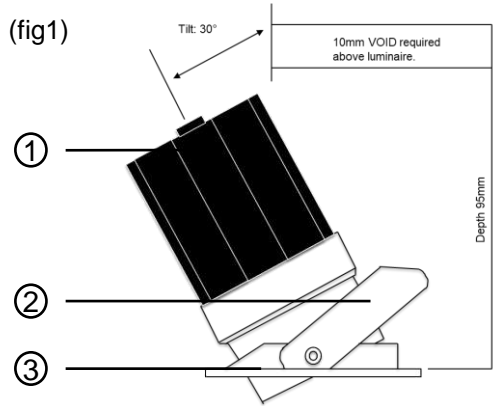

NB. PLEASE ENSURE THERE IS SUFFICIENT SPACE AROUND THE LUMINAIRE TO ALLOW HEAT TO RADIATE FROM THE LIGHT ENGINE. Please allow 10mm above the fitting and 50mm around the sides. DO NOT COVER WITH INSULATION. FULL DETAILS PAGE 5.

Apollo Plaster-In

APB APF APT Cut out Ø 95mm



APB Apollo Plaster-In Base



APF Apollo Plaster-In Fixed



APT Apollo Plaster-In Tilt

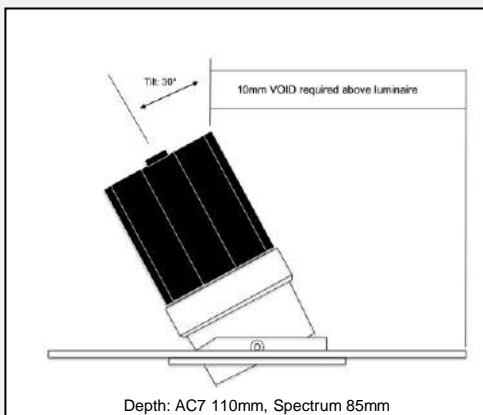
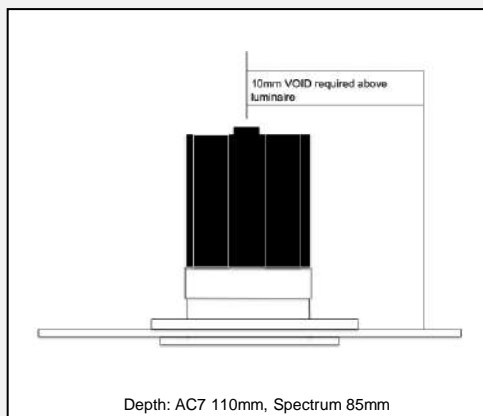
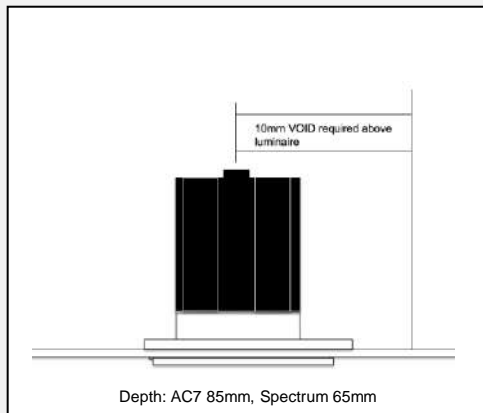

Apollo Plaster-In

APB APF APT Cut out Ø 95mm

- ① Magnetic P-Plate
- ② Luminaire Bezel
- ③ Hole for Plasterboard Screws
- ④ Plaster Skim Ring

We recommend Starrett hole saws. 95mm: FCH0334

1. Ensure your electricity supply is disconnected. **DO NOT CONNECT LEDs TO LIVE DRIVERS OR 240V.**
2. Cut your installation hole to the required cut out size. This can be found above and on the product datasheet. **For TWIN versions see p39.**
3. Fix the magnetic plaster-in plate "P-Plate" (1) to the plasterboard. Use plasterboard screws with wide shallow heads in the screw holes provide (3).
4. Plaster to the outside edge of the plaster skim ring (4), clean and decorate.
5. LED Connection. **Spectrum** light engines may already be connected to the driver. If not please follow wiring diagram on driver.
6. Mains 240v Connection. If the luminaire has not been pre-wired, please follow the diagram on the supplied driver.
7. **AC7** light engines are 240v and should be connected **BLUE** cable to **NEUTRAL**, **BROWN** cable to **LIVE**.
8. Offer the connected luminaire (2) into the central magnetic retention hole and adjust as necessary.

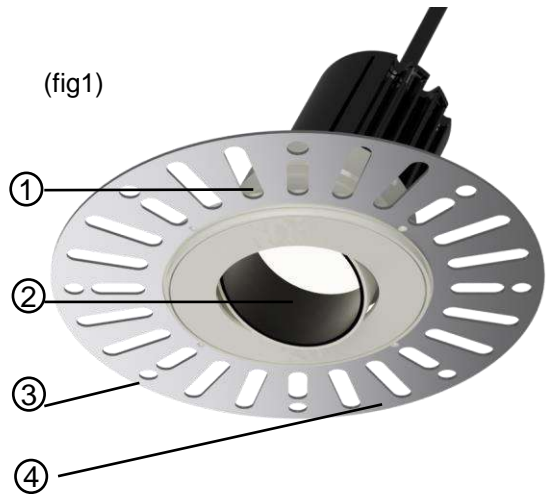

(fig2)

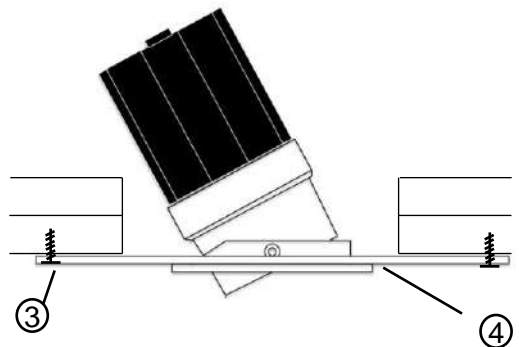

NB. PLEASE ENSURE THERE IS SUFFICIENT SPACE AROUND THE LUMINAIRE TO ALLOW HEAT TO RADIATE FROM THE LIGHT ENGINE. Please allow 10mm above the fitting and 50mm around the sides. **DO NOT COVER WITH INSULATION.** FULL DETAILS PAGE 5.

Apollo Trimless

ATB ATF ATT Cut out Ø 95mm



ATB Apollo Trimless Base



ATF Apollo Trimless Fixed



ATT Apollo Trimless Tilt

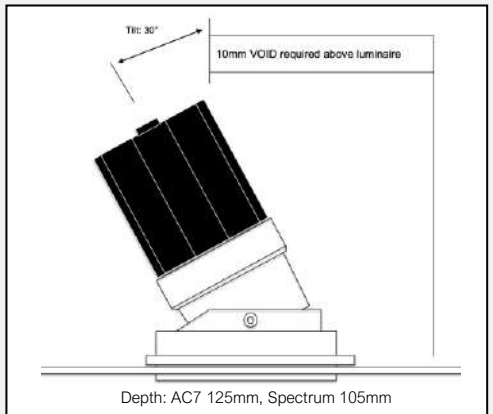
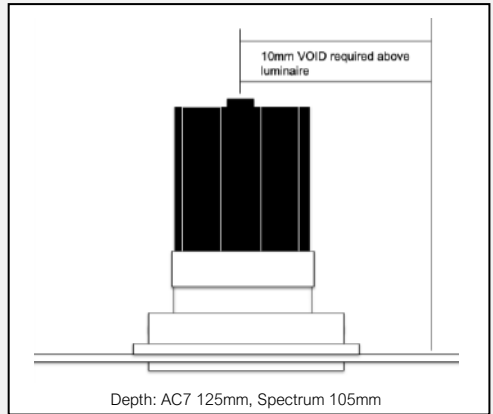
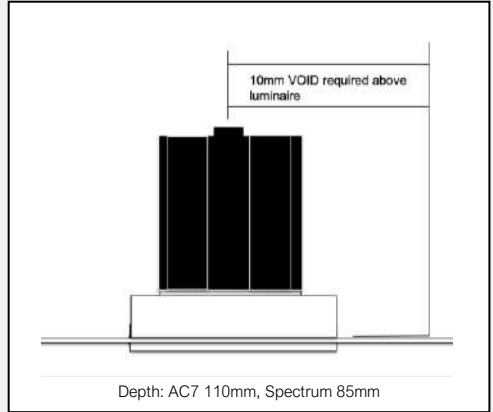

Apollo Trimless

ATB ATF ATT Cut out Ø 95mm

- ① Magnetic T-Plate
- ② Luminaire Bezel
- ③ Hole for Plasterboard Screws
- ④ Plaster Skim Ring

We recommend Starrett hole saws. 95mm: FCH0334

1. Ensure your electricity supply is disconnected. **DO NOT CONNECT LEDs TO LIVE DRIVERS OR 240V.**
2. Cut your installation hole to the required cut out size. This can be found above and on the product datasheet. **For TWIN versions see p39.**
3. Fix the magnetic trimless plaster-in plate "T-Plate" (1) to the plasterboard. Use plasterboard screws with wide shallow heads in the screw holes provide (3).
4. Plaster to the outside edge of the plaster skim ring (4), clean and decorate.
5. LED Connection. **Spectrum** light engines may already be connected to the driver. If not please follow wiring diagram on driver.
6. Mains 240v Connection. If the luminaire has not been pre-wired, please follow the diagram on the supplied driver.
7. **AC7** light engines are 240v and should be connected BLUE cable to NEUTRAL, BROWN cable to LIVE.
8. Offer the connected luminaire (2) into the central magnetic retention hole and adjust as necessary.

(fig1)

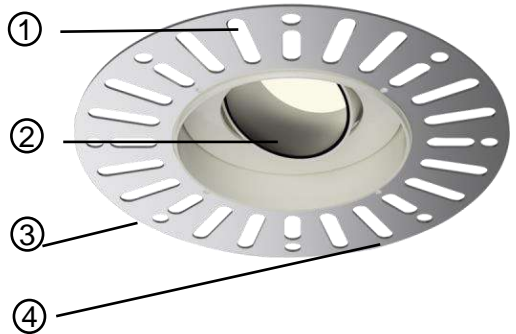

(fig2)

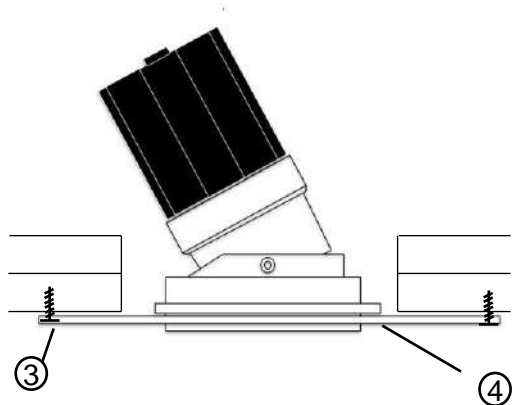

NB. PLEASE ENSURE THERE IS SUFFICIENT SPACE AROUND THE LUMINAIRE TO ALLOW HEAT TO RADIATE FROM THE LIGHT ENGINE. Please allow 10mm above the fitting and 50mm around the sides. DO NOT COVER WITH INSULATION. FULL DETAILS PAGE 5.

Cubitt

CB CRF CRT Cut out: 82 x 82mm

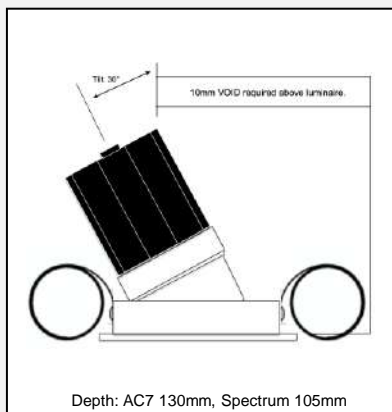
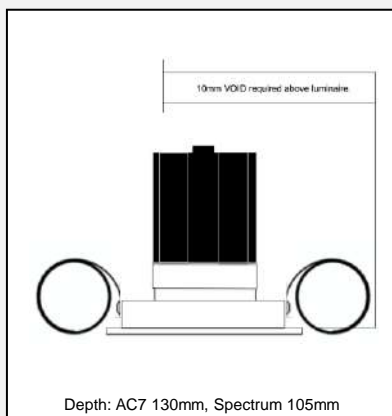
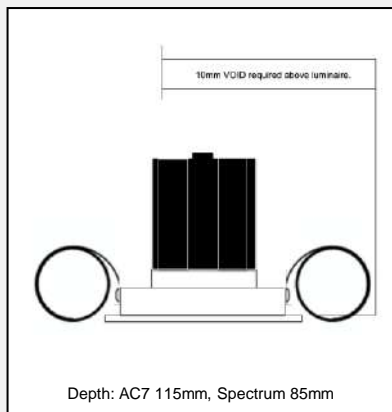

Cubitt Twin

CB CRF CRT Cut out: 82 x 164mm



CB2 Cubitt Base Twin



CRF2 Cubitt Recess Fixed Twin



CRT2 Cubitt Recess Tilt Twin

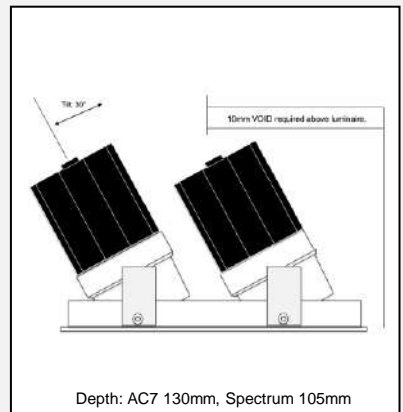
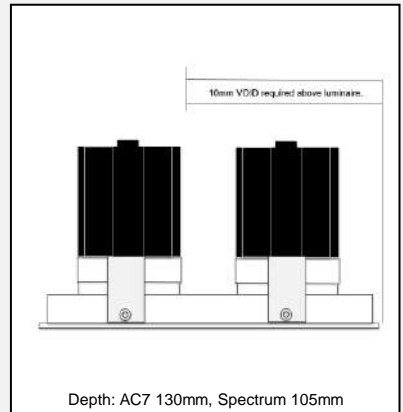
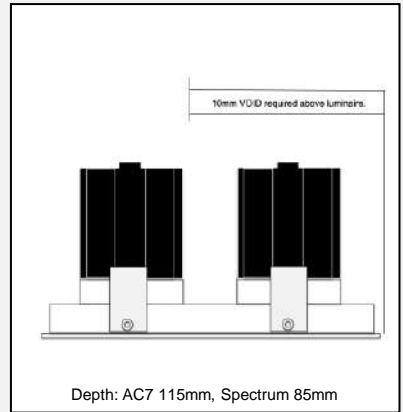

Cubitt

CB CRF CRT Cut out: 82 x 82mm

Cubitt Twin

CB2 CRF2 CRT2 Cut out: 82 x 164mm

- ① Magnetic C-Plate
- ② Luminaire Bezel
- ③ Constant torsion spring
- ④ Pattress / Upper plasterboard layer

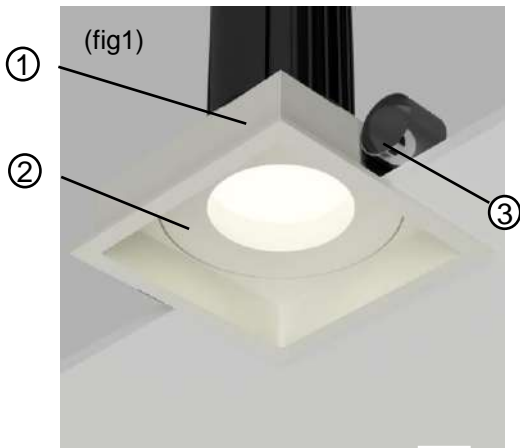

1. Ensure your electricity supply is disconnected. **DO NOT CONNECT LEDs TO LIVE DRIVERS OR 240V.**
2. Cut your installation hole to the required cut out size. This can be found above and on the product datasheet. **N.B. Take special care. The bezel trim is narrow.**

3. Fix the Cubitt "C-Plate" (1) to the ceiling using the constant torsion springs. If the ceiling is single plasterboard you may need to add a pattress (4) above the ceiling to provide the necessary tension for the springs.
4. LED Connection. **Spectrum** light engines may already be connected to the driver. If not please follow wiring diagram on driver.
5. Mains 240v Connection. If the luminaire has not been pre-wired, please follow the diagram on the supplied driver.

6. **AC7** light engines are 240v and should be connected **BLUE** cable to **NEUTRAL**, **BROWN** cable to **LIVE**.

7. Offer the connected luminaire (2) into the central magnetic retention hole and adjust as necessary.

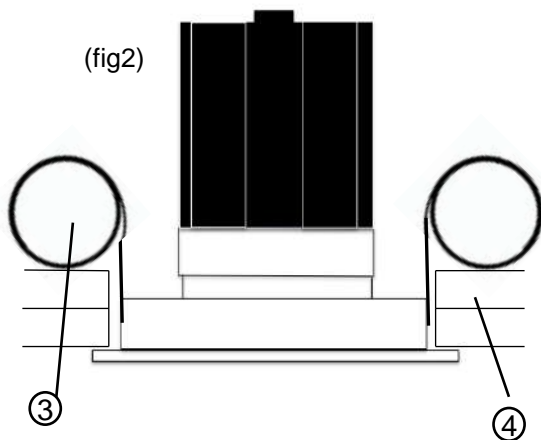

NB. PLEASE ENSURE THERE IS SUFFICIENT SPACE AROUND THE LUMINAIRE TO ALLOW HEAT TO RADIATE FROM THE LIGHT ENGINE. Please allow 10mm above the fitting and 50mm around the sides. DO NOT COVER WITH INSULATION. FULL DETAILS PAGE 5.



Cubitt Trimless

CTB CTF CTT Cut out 82 x 82mm



CTB Cubitt Trimless
Base



CTF Cubitt Trimless
Fixed



CTT Cubitt Trimless
Tilt

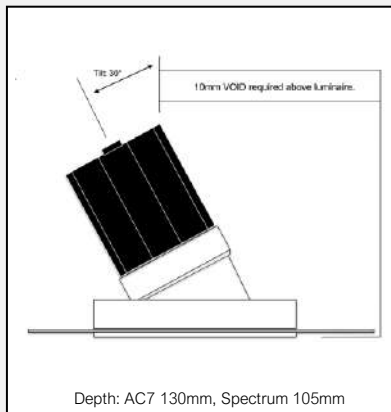
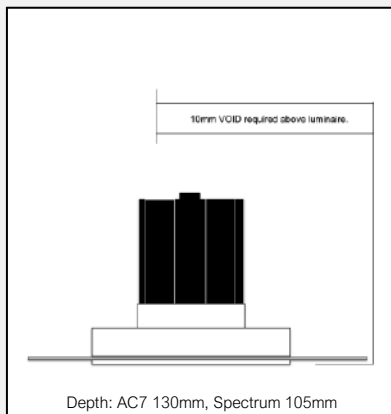
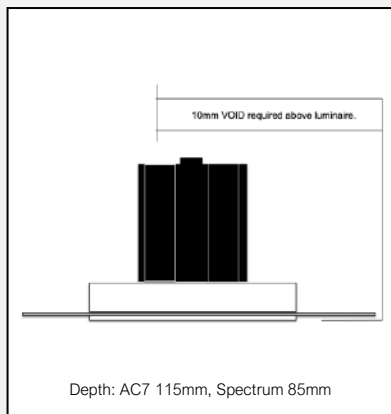

Cubitt Trimless Twin

CB2 CRF2 CRT2 Cut out 82 x 164mm



CTB2 Cubitt Trimless Base Twin



CTF2 Cubitt Trimless Fixed Twin



CTT2 Cubitt Trimless Tilt Twin

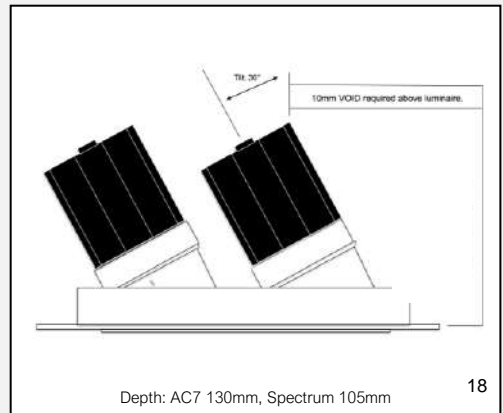
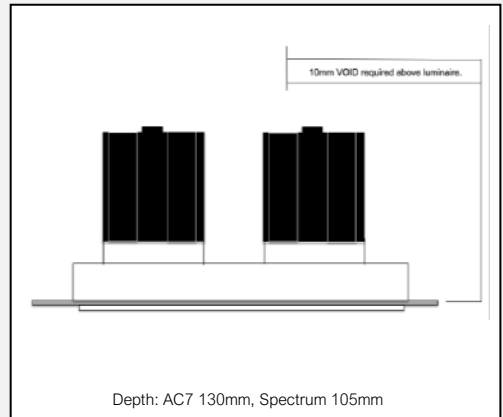
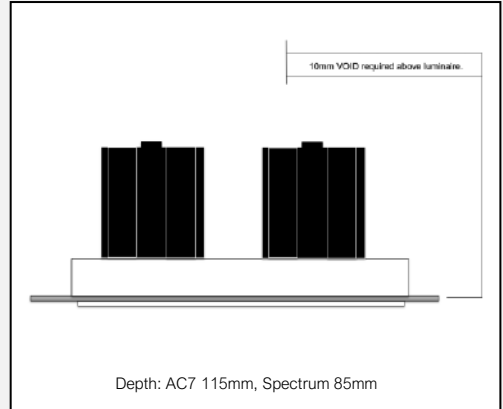

Cubitt Trimless

CTB CTF CTT Cut out: 92 x 92mm

Cubitt Trimless Twin

CTB2 CTF2 CTT2 Cut out: 92 x 184mm

- ① Magnetic Plaster-in CT-Plate
- ② Luminaire Bezel
- ③ Hole for plasterboard screws
- ④ Plaster Skim Detail
- ⑤ Light Engine

(fig1)

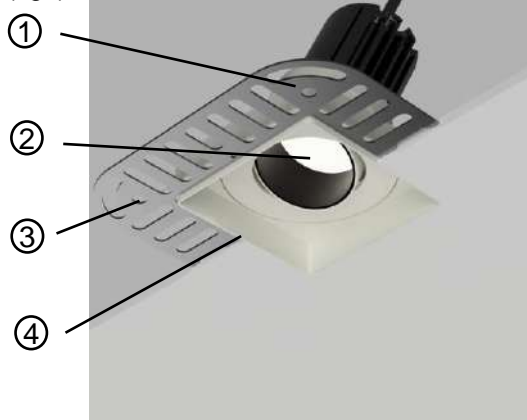

1. Ensure your electricity supply is disconnected. **DO NOT CONNECT LEDs TO LIVE DRIVERS OR 240V.**
2. Cut your installation hole to the required cut out size. This can be found above and on the product datasheet. **N.B. Trimless luminaires require special care.**
3. Fix the magnetic trimless plaster-in plate "CT-Plate" (1) to the plasterboard. Use plasterboard screws with wide shallow heads in the screw holes provide (3).
4. Plaster to the outside edge of the plaster skim ring (4), clean and decorate.
5. LED Connection. **Spectrum** light engines may already be connected to the driver. If not please follow wiring diagram on driver.
6. Mains 240v Connection. If the luminaire has not been pre-wired, please follow the diagram on the supplied driver.
7. **AC7** light engines are 240v and should be connected **BLUE** cable to **NEUTRAL**, **BROWN** cable to **LIVE**.
8. Offer the connected luminaire bezel (2) into the central magnetic retention hole and adjust as necessary.

(fig2)

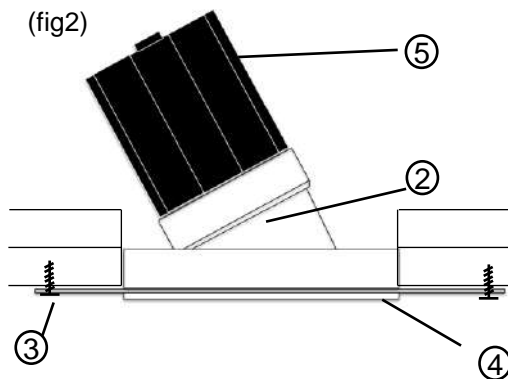

NB. PLEASE ENSURE THERE IS SUFFICIENT SPACE AROUND THE LUMINAIRE TO ALLOW HEAT TO RADIATE FROM THE LIGHT ENGINE. Please allow 10mm above the fitting and 50mm around the sides. DO NOT COVER WITH INSULATION. FULL DETAILS PAGE 5.

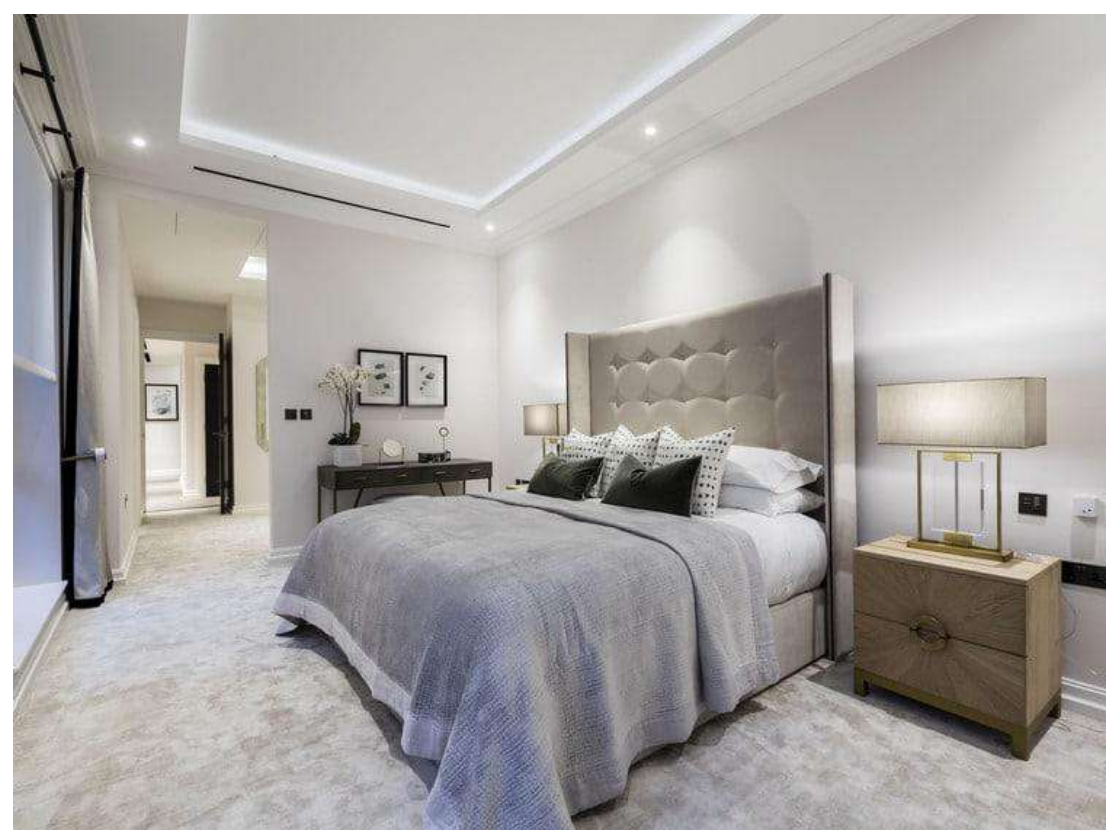

Delta

DB DRF DRT Cut out Ø 73mm



DB Delta Base

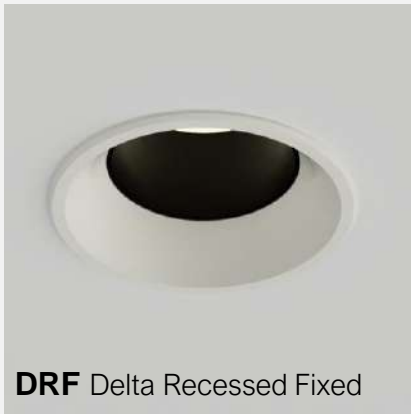

DRF Delta Recessed Fixed

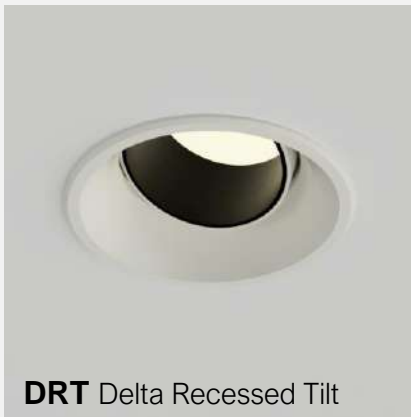

DRT Delta Recessed Tilt

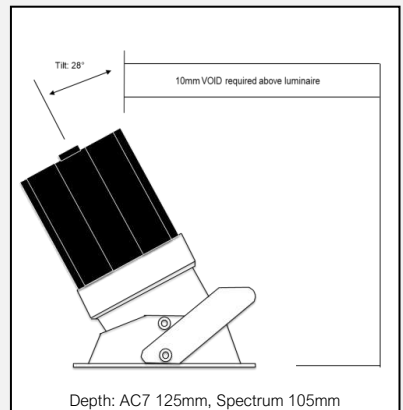
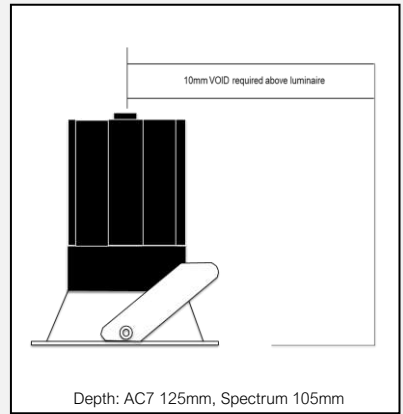
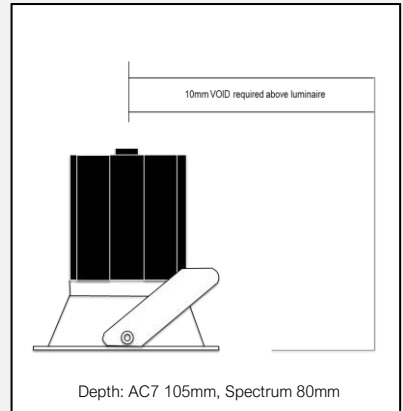

Delta

DB DRF DRT Cut out Ø 73mm

- ① Light Engine
- ② Retention Springs
- ③ Luminaire Bezel
- ④ Plasterboard – Upper Layer
- ⑤ Plasterboard – Lower Layer

We recommend Starrett hole saws. 73mm: FCH0278

1. Ensure your electricity supply is disconnected.
DO NOT CONNECT LEDs TO LIVE DRIVERS OR 240V.
2. Cut your installation hole to the required cut out size. This can be found above and on the product datasheet.
3. Our luminaires are suitable for single and double plasterboard ceilings. If the upper layer of plasterboard prevents the retention springs engaging you will need to cut it back. (4). To achieve full tilt adjustment you may need to chamfer the lower layer of plasterboard (5). See fig. 2.
4. LED Connection. **Spectrum** light engines may already be connected to the driver. If not please follow wiring diagram on driver.
5. Mains 240v Connection. If the luminaire has not been pre-wired, please follow the diagram on the supplied driver.
6. **AC7** light engines are 240v and should be connected BLUE cable to NEUTRAL, BROWN cable to LIVE.
7. Offer connected luminaire into the ceiling hole gripping the retention springs (2). Release the springs. Adjust so that the bezel (3) fits snugly in the hole. The bezel (3) can be rotated anti-clockwise to achieve a tighter fit.

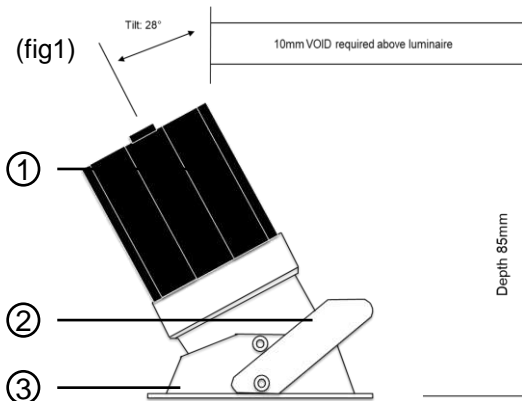

(fig2)

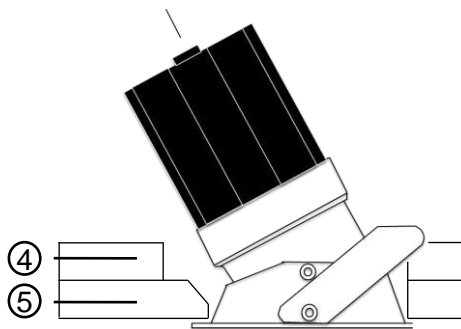

NB. PLEASE ENSURE THERE IS SUFFICIENT SPACE AROUND THE LUMINAIRE TO ALLOW HEAT TO RADIATE FROM THE LIGHT ENGINE. Please allow 10mm above the fitting and 50mm around the sides. DO NOT COVER WITH INSULATION. FULL DETAILS PAGE 5.

Delta Trimless

DTB DTF DTT Cut out Ø 95mm



DTB Delta Trimless Base



DTF Delta Trimless Fixed



DTT Delta Trimless Tilt

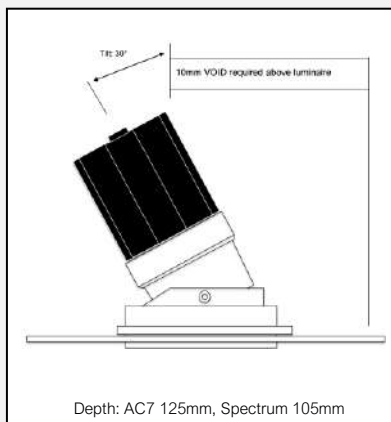
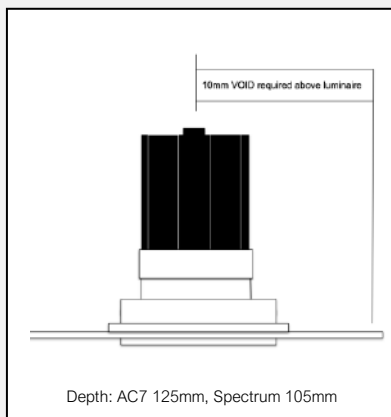
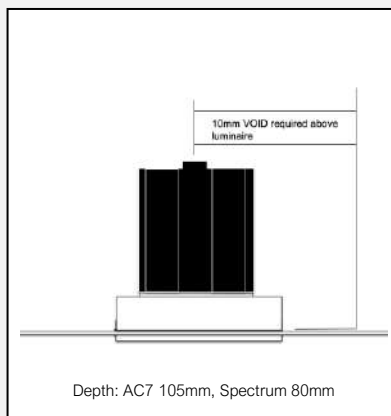

Delta Trimless

DTB DTF DTT Cut out Ø 95mm

- ① Magnetic T-Plate
- ② Luminaire Bezel
- ③ Hole for Plasterboard Screws
- ④ Plaster Skim Ring

We recommend Starrett hole saws. 95mm: FCH0334

1. Ensure your electricity supply is disconnected. **DO NOT CONNECT LEDs TO LIVE DRIVERS OR 240V.**
2. Cut your installation hole to the required cut out size. This can be found above and on the product datasheet. **For TWIN versions see p39.**
3. Fix the magnetic trimless plaster-in plate "T-Plate" (1) to the plasterboard. Use plasterboard screws with wide shallow heads in the screw holes provide (3).
4. Plaster to the outside edge of the plaster skim ring (4), clean and decorate.
5. LED Connection. **Spectrum** light engines may already be connected to the driver. If not please follow wiring diagram on driver.
6. Mains 240v Connection. If the luminaire has not been pre-wired, please follow the diagram on the supplied driver.
7. **AC7** light engines are 240v and should be connected BLUE cable to NEUTRAL, BROWN cable to LIVE.
8. Offer the connected luminaire (2) into the central magnetic retention hole and adjust as necessary.

(fig1)

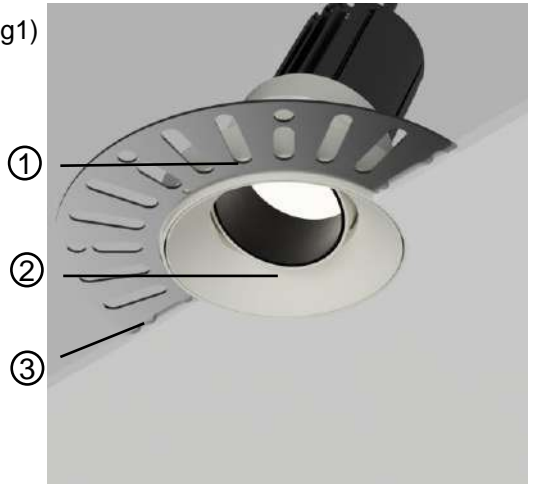

(fig2)

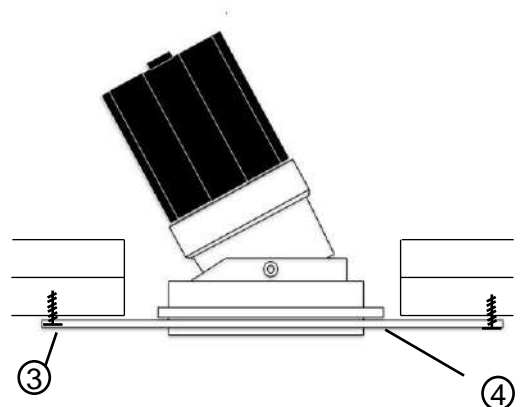

NB. PLEASE ENSURE THERE IS SUFFICIENT SPACE AROUND THE LUMINAIRE TO ALLOW HEAT TO RADIATE FROM THE LIGHT ENGINE. Please allow 10mm above the fitting and 100mm around the sides. DO NOT COVER WITH INSULATION. FULL DETAILS P5.

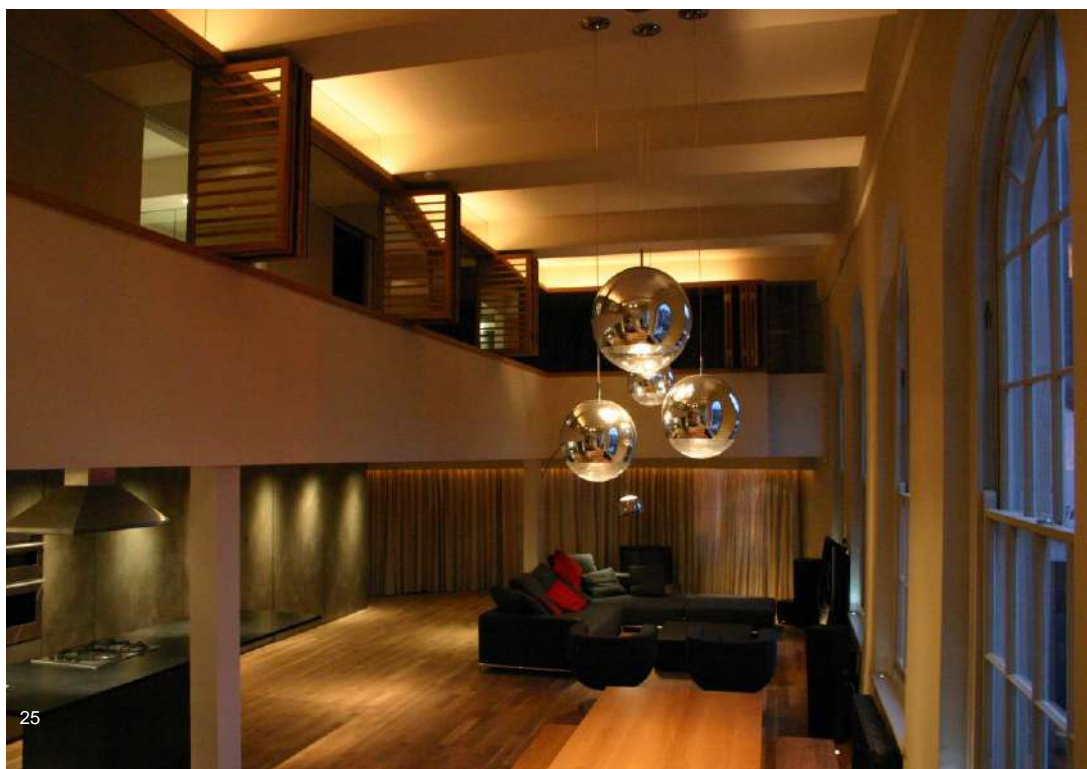



Ghost Trimless

GTF GTR Cut out Ø 95mm



GTF Ghost Trimless Flush



GTR Ghost Trimless Recess

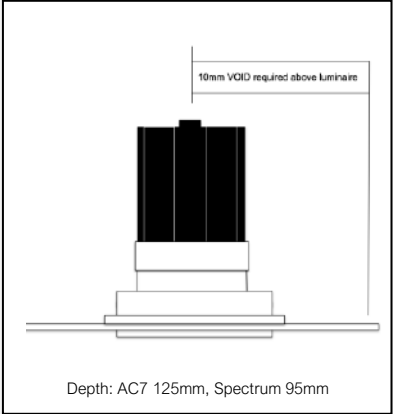
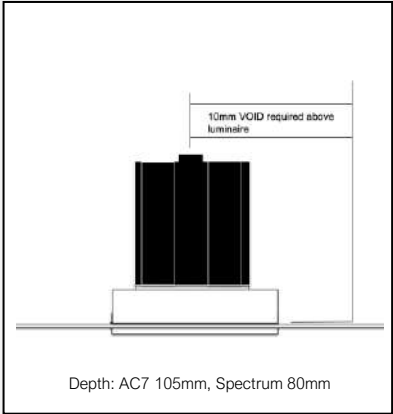

Ghost Trimless

GTF GTR Cut out Ø 95mm

- ① Magnetic T-Plate
- ② Luminaire Bezel
- ③ Hole for Plasterboard Screws
- ④ Plaster Skim Ring

We recommend Starrett hole saws. 95mm: FCH0334

1. Ensure your electricity supply is disconnected. **DO NOT CONNECT LEDs TO LIVE DRIVERS OR 240V.**
2. Cut your installation hole to the required cut out size. This can be found above and on the product datasheet. **For TWIN versions see p39.**
3. Fix the magnetic trimless plaster-in plate "T-Plate" (1) to the plasterboard. Use plasterboard screws with wide shallow heads in the screw holes provide (3).
4. Plaster to the outside edge of the plaster skim ring (4), clean and decorate.
5. LED Connection. **Spectrum** light engines may already be connected to the driver. If not please follow wiring diagram on driver.
6. Mains 240v Connection. If the luminaire has not been pre-wired, please follow the diagram on the supplied driver.
7. **AC7** light engines are 240v and should be connected BLUE cable to NEUTRAL, BROWN cable to LIVE.
8. Offer the connected luminaire (2) into the central magnetic retention hole and adjust as necessary.

(fig1)

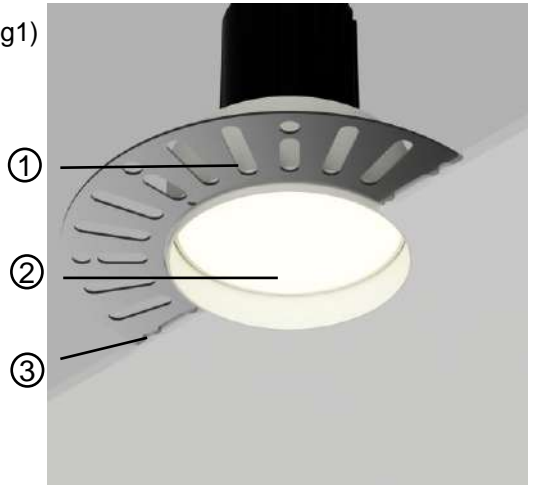

(fig2)

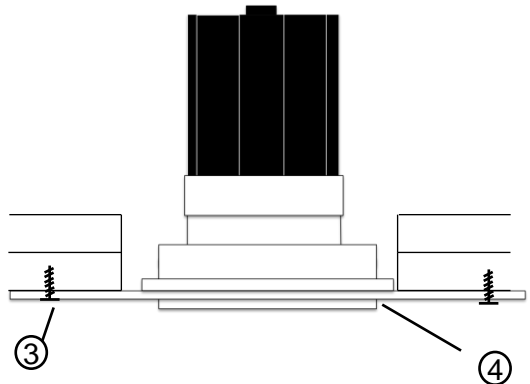

NB. PLEASE ENSURE THERE IS SUFFICIENT SPACE AROUND THE LUMINAIRE TO ALLOW HEAT TO RADIATE FROM THE LIGHT ENGINE. Please allow 10mm above the fitting and 50mm around the sides. DO NOT COVER WITH INSULATION. FULL DETAILS PAGE 5.

Ghost Trimless Wallwasher

GTW Cut out Ø 95 x 120mm



GTW Ghost Trimless
Wallwasher

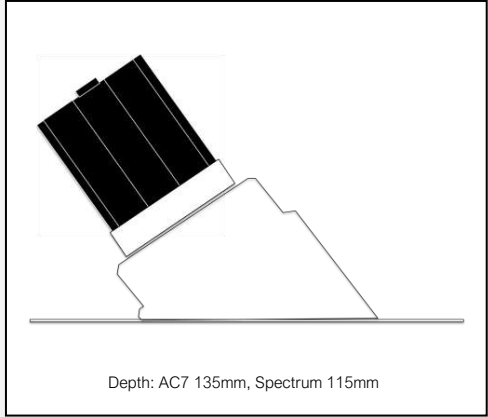

Depth: AC7 135mm, Spectrum 115mm

Ghost Trimless Wallwasher

GTW Cut out Ø 95 x 120mm

- ① Magnetic T-Plate
- ② Luminaire Bezel
- ③ Hole for Plasterboard Screws
- ④ Plaster Skim Ring

1. Ensure your electricity supply is disconnected.
DO NOT CONNECT LEDs TO LIVE DRIVERS OR 240V.
2. Cut your installation hole to the required cut out size. This can be found above and on the product datasheet.
3. Fix the magnetic trimless plaster-in plate "T-Plate" (1) to the plasterboard. Use plasterboard screws with wide shallow heads in the screw holes provide (3).
4. Plaster to the outside edge of the plaster skim ring (4), clean and decorate.
5. LED Connection. **Spectrum** light engines may already be connected to the driver. If not please follow wiring diagram on driver.
6. Mains 240v Connection. If the luminaire has not been pre-wired, please follow the diagram on the supplied driver.
7. **AC7** light engines are 240v and should be connected BLUE cable to NEUTRAL, BROWN cable to LIVE.
8. Offer the connected luminaire (2) into the central magnetic retention hole and adjust as necessary.

(fig1)

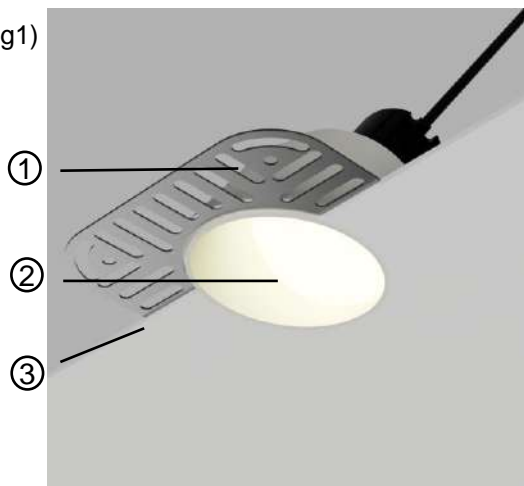

(fig2)

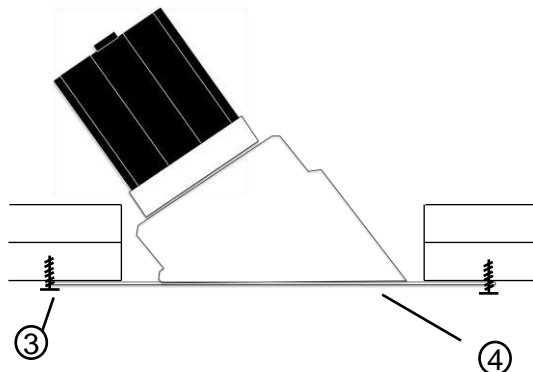

NB. PLEASE ENSURE THERE IS SUFFICIENT SPACE AROUND THE LUMINAIRE TO ALLOW HEAT TO RADIATE FROM THE LIGHT ENGINE. Please allow 10mm above the fitting and 50mm around the sides. DO NOT COVER WITH INSULATION. FULL DETAILS PAGE 5.

Orbit

Ø OSS OBZ Cut out Ø 64mm



○ Orbit



OSS Orbit Stainless Steel



OBZ Orbit Unfinished Bronze

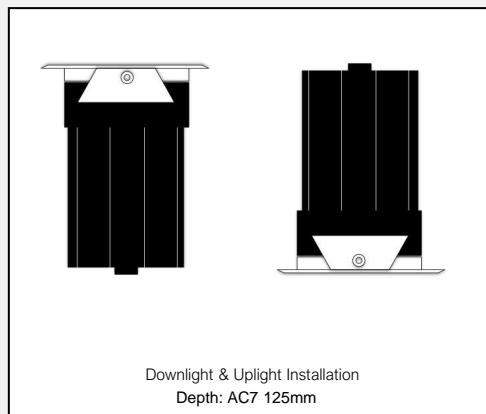
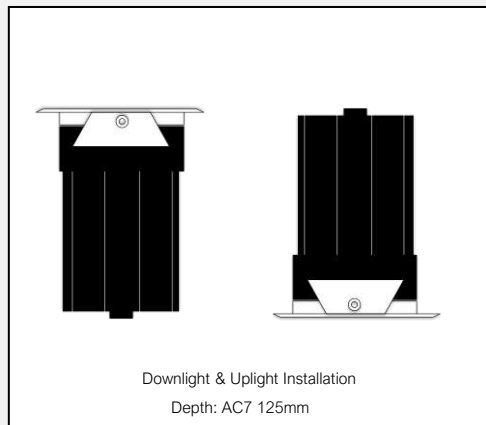
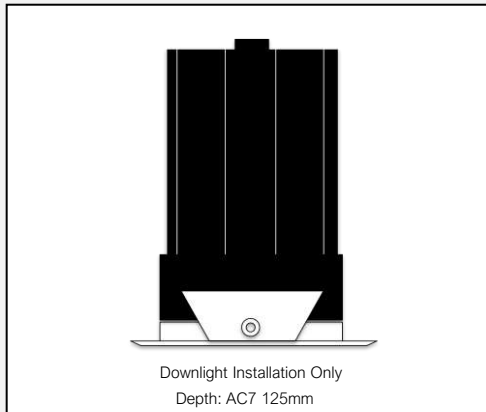

We recommend Starrett hole saws. 64mm: FCH0212

Downlight Installation Uplight Installation (Floorboard)

1. Ensure your electricity supply is disconnected.
2. Cut your installation hole to the required cut out size. This can be found above and on the product datasheet.
3. Our luminaires are suitable for single and double plasterboard ceilings.
4. AC7 light engines with integral drivers are 240v and should be connected BLUE cable to NEUTRAL, BROWN cable to LIVE.
5. Offer connected luminaire into the hole gripping the retention springs. Release the springs. Adjust so that the bezel fits snugly in the hole.

Uplight Installation Screeded Floor

1. Before the floor is laid ensure that an electrical termination has been provided for each luminaire position.
2. Installation tube: Orbit is designed to fit into standard size 2.5" / 75mm outer diameter plastic tubing. Colourbox can provide a 300mm length of tube which can be cut to length on site.
3. Place installation tube at the correct position ensuring that the electrical feed is present and that any necessary cable holes are drilled into the tube.
4. If the floor is surfaced with tiles or wood, cut an installation hole to the required cut out size. This can be found above and on the product datasheet.
5. AC7 light engines with integral drivers are 240v and should be connected BLUE cable to NEUTRAL, BROWN cable to LIVE.
6. Offer connected luminaire into the hole gripping the retention springs. Release the springs. Adjust so that the bezel fits snugly in the hole.

N.B.
Orbit is **ONLY** suitable for *uplight* installation indoors.
Do **NOT** install outdoors.

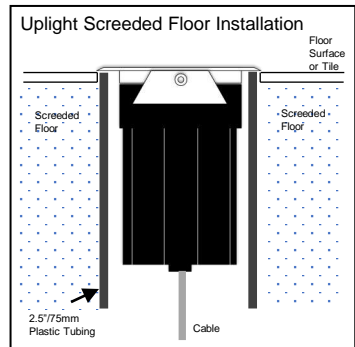
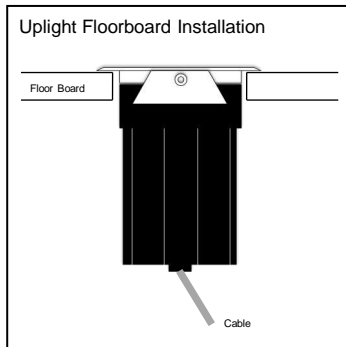
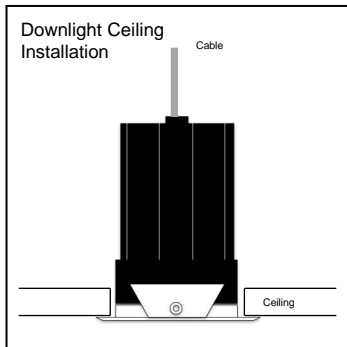

CBXL Linear

CBXL-HD High Density 280 LEDs/m

CBXL-LD Low Density 120 LEDs/m

CBXL-AMB Ambient Dim to Warm

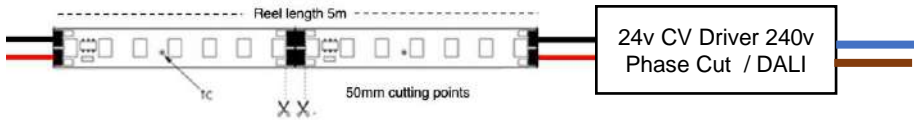

1. **DO NOT CONNECT LEDs TO LIVE DRIVERS OR 240V.** Ensure your mains supply is disconnected.
2. Cut the tape to the required length. Cutting points are marked on the tape. A sharp cutting tool such as scissors or side cutters must be used. Care must be taken not to twist or coil the tape off the reel. **This can result in PCB damage and will invalidate our FIVE year guarantee.**
3. Ensure the mounting surface is clean and dry then remove the protective coating from the adhesive strip. Carefully fix to the mounting surface, Colourbox flexible LED strips must be mounted on a suitable surface (ideally an aluminium profile) to ensure optimum thermal performance. **This is a requirement of our FIVE year guarantee.**
4. Colourbox flexible LED strips requires 24v Constant Voltage drivers. Choose an appropriate wattage to the specific length of tape. Multiple tape lengths may be powered by a single driver when wired in parallel. When wiring observe polarity.
5. Colourbox flexible LED strips are pre-wired at each end of the reel. Off cuts can then be soldered on site to minimise waste.
6. Connection cables can be manually soldered on site (max 2 seconds at 260°). Take care to observe polarity.
7. The protective tape must be removed before using snap on connectors or soldering.

CBXL-TW Tuneable White

fig. 1



fig. 2

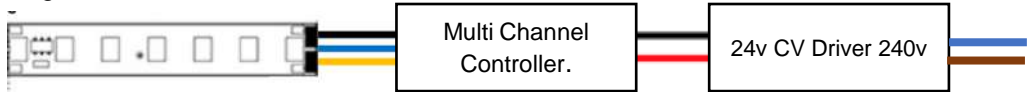

1. **DO NOT CONNECT LEDs TO LIVE DRIVERS OR 240V.** Ensure your mains supply is disconnected.
2. Cut the LED strip to the required length. Cutting points are marked on the upper surface. A sharp cutting tool such scissors or side cutters must be used. Care must be taken not to twist or coil the tape off the reel. **This can result in PCB damage and will invalidate our FIVE year guarantee.**
3. Ensure the mounting surface is clean and dry then remove the protective coating from the adhesive strip. Carefully fix to the mounting surface, Colourbox flexible LED strips must be mounted on a suitable surface (ideally an aluminium profile) to ensure ideal thermal performance. **This is a requirement of our FIVE year guarantee.**
4. Colourbox TW flexible LED strips require a either a DALI DT8 driver (fig 1) which controls both colour channels or multi channel controller powered by a suitable 24v constant voltage driver (fig 2).
5. Colourbox TW flexible LED strips are pre-wired at each end of the reel.

CBXL Linear

CBXL - RGBW

fig. 1

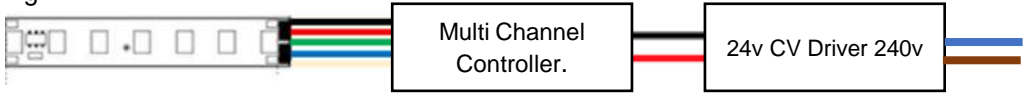

CBXL - RGB

fig. 2

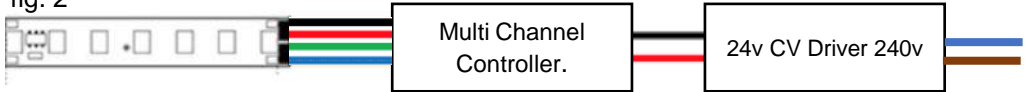

-
1. **DO NOT CONNECT LEDs TO LIVE DRIVERS OR 240V.** Ensure your mains supply is disconnected.
 2. Cut the tape to the required length. Cutting points are marked on the tape. A sharp cutting tool such as a scissors or side cutters must be used. Care must be taken not to twist or coil the tape off the reel. **This can result in PCB damage and will invalidate our FIVE year guarantee.**
 3. Ensure the mounting surface is clean and dry then remove the protective coating from the adhesive strip. Carefully fix to the mounting surface, Colourbox flexible LED strips must be mounted on a suitable surface (ideally an aluminium profile) to ensure ideal thermal performance. **This is a requirement of our FIVE year guarantee.**
 4. RGBW and RGB LED strips require a multi channel controller. This is connected between the tape and the 24v driver. See figs 1 & 2.
 5. RGBW and RGB LED strips are pre-wired at each end of the 5m reel.





Dimming & Control

Mains Dimming

Mains Dim Drivers.

Our mains dim drivers are suitable for leading and trailing edge dimmers.

Rotary Dimmers

Use only dimmer modules designed for LED loads. Legacy dimmers for halogen and other incandescent lamps are not suitable for LEDs. Care must be taken to ensure the minimum and maximum load on the circuit matches the specification of the dimmer module. Colourbox recommends Varilight V-Pro dimmer modules.



Dimming Systems

Colourbox mains dim products are approved by Lutron and have been tested with many other systems including Wandsworth, Casambi, Systemteq Control4 and Rako.

DALI Dimming

Wiring & Programming

It is important to ensure that the project has been wired for DALI and that an experienced DALI programming engineer is appointed to commission the system.

A good programmer will ensure that the system makes full use of the extensive functionality available from DALI control systems.

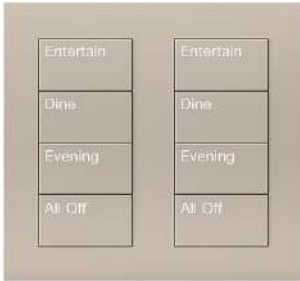

0-10v Dimming

Wiring & Programming

It is important to ensure that the project has been wired correctly for 0-10v control and that the installer is familiar with this type of installation.

Colourbox Dimming Guarantee

Dimming systems are continually updated and new systems frequently enter the market.

Colourbox can undertake testing to ensure our products work seamlessly with your system.

Contact us to discuss your project at info@colourbox.studio



Twin Cut Outs & Centres

Apollo Plaster-In Twin
APB2 APF2 APT2

Apollo Trimless Twin
ATB2 ATF2 ATT2

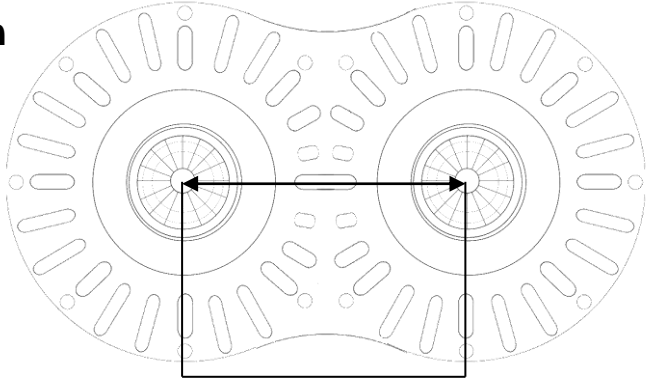

2 x 95mm Cut Outs @ 110mm Centres

Delta Trimless Twin
DTB2 DTF2 DTT2

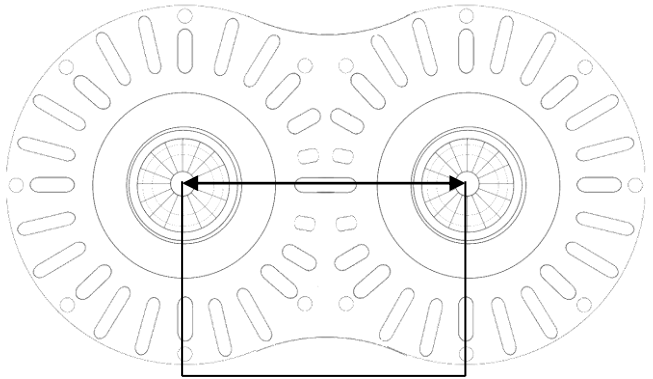

2 x 95mm Cut Outs @ 110mm Centres

Ghost Trimless Twin
GTF2 GTR2

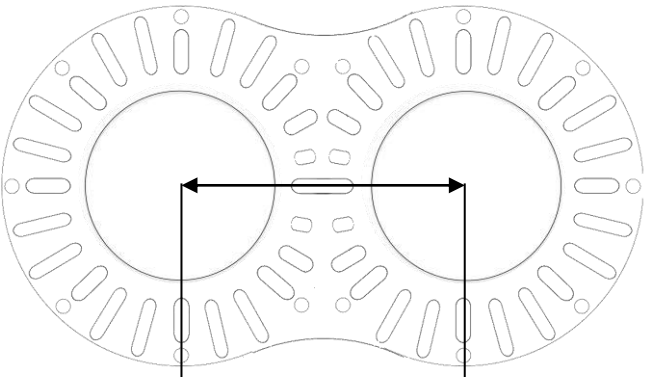

2 x 95mm Cut Outs @ 110mm Centres

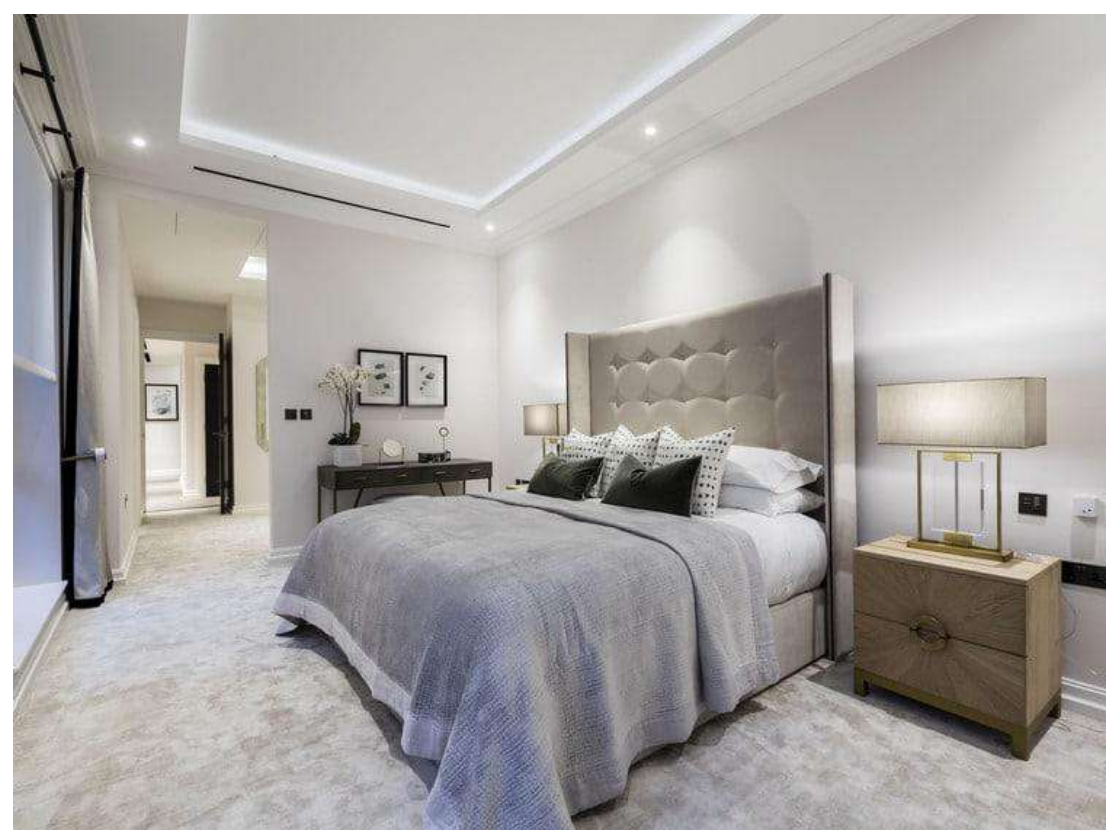



COLOURBOX.STUDIO

Colourbox Studio Ltd
52 St Mary's Road
Faversham
Kent
ME13 8EH

01795 505370
info@colourbox.studio
www.colourbox.studio



**MADE IN
BRITAIN**